

# Elite 1 - N

**Analogue Addressable  
Fire Control Panel  
for  
Nittan Protocol**

***Installation and Commissioning  
Manual***

**Software v1.04 and above**

**MASTER  
MANUAL**

# Contents

Introduction .....	4
About this manual .....	4
Description .....	5
General .....	5
Panel Controls (see figure 1 page 5) .....	6
Panel Indicators (see figure 1 page 5) .....	7
Control panel fascia .....	8
LCD Display .....	9
Access Levels .....	10
Main PCB .....	11
General .....	11
Features .....	11
Main PCB layout .....	13
Important - Read this section first! .....	14
Safety .....	14
General .....	14
Installation .....	14
Mounting the Cabinet .....	15
Cabling .....	15
Power Supply .....	15
Field Devices .....	15
Commissioning .....	16
General .....	16
Field devices .....	16
Device address .....	16
Loop wiring .....	17
Powering the panel .....	18
Mains connection .....	18
Connecting the battery .....	19
Starting the panel on battery power .....	19
Initialisation .....	20
Clock battery .....	22
Sounder circuits .....	22
Remote contacts .....	22
Remote outputs .....	23
Remote inputs .....	23
Optional zonal outputs .....	24
Remote power supply .....	24
CPU Reset .....	25
Checking the system .....	25
Clear ARW .....	25
Operation - Fire Alarm .....	26
Normal .....	26
Fire Alarm .....	26
Silencing the alarm .....	27
Resounding the alarm .....	27
Resetting the system .....	27
Panel buzzer .....	28
Operation - General .....	28

Evacuate .....	28
Operation - Fault .....	29
Monitoring .....	29
Fault condition .....	29
Panel functions .....	30
General .....	30
Function buttons .....	30
Level 2 Options menu .....	30
Menu Option procedures .....	31
Enable/disable remote outputs .....	32
Manual .....	32
Auto enablement .....	33
Enable/disable zones .....	34
Manual .....	34
Auto enablement .....	35
Enable/disable address .....	36
Individual device isolation .....	36
Disable sounders .....	37
Set time and date .....	38
View active disablements .....	39
View Active Faults .....	40
Zone Test .....	41
Change Access Level .....	42
Select heat sensor grades .....	43
Repeaters on line .....	44
Examine event store .....	45
Print event store .....	46
Clear event store .....	47
Print loop status .....	48
Transmission test mode .....	49
Exit level 3 menus .....	51
Maintenance check .....	51
Fault messages .....	52
Configuration .....	53
Introduction .....	53
Zones .....	53
Device configuration .....	54
Device types and responses: .....	54
Panel configuration .....	57
Device edit .....	57
Group edit .....	58
Text edit .....	58
Edit Group Type/Default Ring Mode .....	59
PC Configuration .....	60
Introduction .....	60
Before you start .....	60
System requirements (DOS version) .....	60
Running the program .....	61
Configuration options .....	62
Overview of PC Configuration options .....	62
Creating a new configuration file .....	65
Editing an existing file .....	69
Replacing the novram .....	70

# Introduction

---

The Surveyor Elite 1 is a single loop, analogue/addressable fire alarm control panel equipped with sixteen zones. It operates with the Nittan-AS protocol and supports the Nittan range of field devices. Two internal sounder circuits are provided and additional sounder circuits can be connected to loop wired modules.

The control panel is programmable via the function keys on the fascia, or via a PC allowing the configuration to be created off-site and downloaded.

## About this manual

---

The manual is intended as a complete guide to the installation, commissioning and operation of the Surveyor Elite 1 fire alarm control panel. A separate Operating manual is supplied with the control panel which in addition to explaining the operation of the panel, incorporates a log book and details of the user's responsibilities for testing and maintaining the system. It is intended that the Operating manual forms part of the documentation package passed to the customer on completion.

This manual provides information for installing and commissioning the control panel. The Nittan field devices are referred to for configuration purposes, but the manufacturer's literature should be consulted for installation and operational data.

It is assumed that users of this manual are competent fire alarm engineers with experience of fire alarm installation and the relevant standards. It is recommended that the manual is read and understood before attempting to commission or configure the control panel. The system should be thoroughly tested following commissioning and prior to handover to confirm that it operates in accordance with the specification and applicable legislation.

# Description

---

## *General*

The control panel is a single loop, sixteen zone analogue/addressable unit with integral power supply and space for a standby battery. It has two sounder circuits, auxiliary voltfree contacts and various remote inputs and outputs.

The control panel comprises a sheet steel enclosure suitable for wall mounting with a hinged, lockable front access door. It can be semi-recessed if required by using a suitable flushing bezel. Cable entry is via the top or rear of the cabinet. 20mm 'knockouts' are provided in the top and cut-outs in the rear.

A common key fits both the door lock and the 'control enable' key switch. A 2 x 40 character, backlit LCD is fitted to display event information and function and configuration menus. Alarm and status information is provided by LED indicators and there are five control pushbuttons which control the system and access the function and configuration options.

The control panel operates with the Nittan protocol and supports the AS detection devices. The full range of detectors, sounder controllers, I/O modules, conventional zone monitors, etc can be incorporated into the system. In addition to the sixteen fire zones, there are three further options Alarms, Contacts and Inputs, which have special functions enabling auxiliary devices to be configured for alternative operation.

It is possible to power the panel from a remote power supply if required and input terminals are provided to facilitate the remote supply input and also to monitor the unit for mains and battery failure.

Access to the panel functions and configuration options is at different levels enabling restricted access to certain functions. At the user level it is possible to disabled parts of the system, set the time and date, put the system into walktest mode and view the system status. Advanced options include configuration, maintenance checks and fault finding mode.

The control panel incorporates an 'auto-learn' feature which enables the system devices to be recognised on initial power up. Configuration of the system operation can be achieved via the panel controls or by downloading data created in a PC software program.

# Panel Controls (see figure 1 page 5)

---

The following control switches are provided on the panel fascia to enable alarm and fault conditions to be processed, and to access the panel functions:

## CONTROLS OFF/ON

This key switch is normally in the OFF position with the key withdrawn and stored where it can be accessed by authorised personnel in the event of an alarm or fault.

For the pushbutton controls to be operable, the key switch must be operated to the ON position.

**NOTE:** It is not possible to withdraw the key in the ON position.

## SILENCE

The **Silence** button has two functions:

- a) In an alarm condition, pressing the **Silence** button silences the sounders on the system.
- b) In a fault condition, pressing the **Silence** button changes the pulsing buzzer to an intermittent tone.

## RESET

The **Reset** button is pressed to restore the system to normal operation following an alarm condition. The Reset button doubles as a lamp test function button and illuminates all the LEDs when pressed. A lamp test can be carried out at any time.

It is also used in the engineering mode to select menu options and enter instructions.

## EVACUATE

Pressing the **Evacuate** button causes the sounders to operate irrespective of whether there is a fire condition existing.

## SCROLL

The **Scroll** button is used to view events when more than one exists on the system.

It is also used in the engineering mode to change data.

## OPTION

The **Option** button is used to invoke the main function menu and to select menu options.

## Panel Indicators (see figure 1 page 5)

---

All the panel indicators are LED type and are coloured according to their function. Fire alarm indicators are red, the 'Healthy' indicator is green, and all other fault/abnormal indicators are yellow. Fire and fault indicators initially flash on alarm and go steady when the Silence button is pressed.

<b>SUPPLY HEALTHY</b>	Normally illuminated to indicate the system is operating correctly. It is extinguished if the mains supply fails and the system is operating on batteries.
<b>SILENCED</b>	Illuminates in conjunction with the <b>Silence</b> pushbutton to indicate the system status.
<b>CPU FAULT</b>	Indicates a critical panel fault which requires immediate attention.
<b>MORE</b>	Indicates there are more events to be viewed by operating the <b>Scroll</b> button.
<b>ARW</b>	Automatic Reset Warning - must be reset to clear.
<b>TEST MODE</b>	Indicates the system is in engineer's test mode.
<b>REMOTE SIGNAL ISOLATED</b>	Indicates that the remote fire output has been isolated for maintenance or testing.
<b>SOUNDER FAULT</b>	Indicates a fault on a sounder circuit.
<b>SYSTEM FAULT</b>	Indicates a fault on the system and may be accompanied by other fault indicators, depending on the condition.
<b>BUZZER SILENCED</b>	Indicates the buzzer has been silenced in a fault indication.
<b>DISABLED</b>	Indicates that part of the system is disabled (isolated).
<b>REMOTE SIGNAL</b>	Indicates that the remote output relay is active on the system.
<b>PRE-ALARM</b>	Indicates a detector has reported a higher than normal analogue value which could signal an impending fire condition.
<b>COMMON FIRE</b>	Twin LEDs that illuminate in any fire condition and when the <b>Evacuate</b> button is activated.
<b>ZONE FIRE</b>	Sixteen indicators (Zones 1-16) to indicate which area (group of devices) has activated in a fire condition.

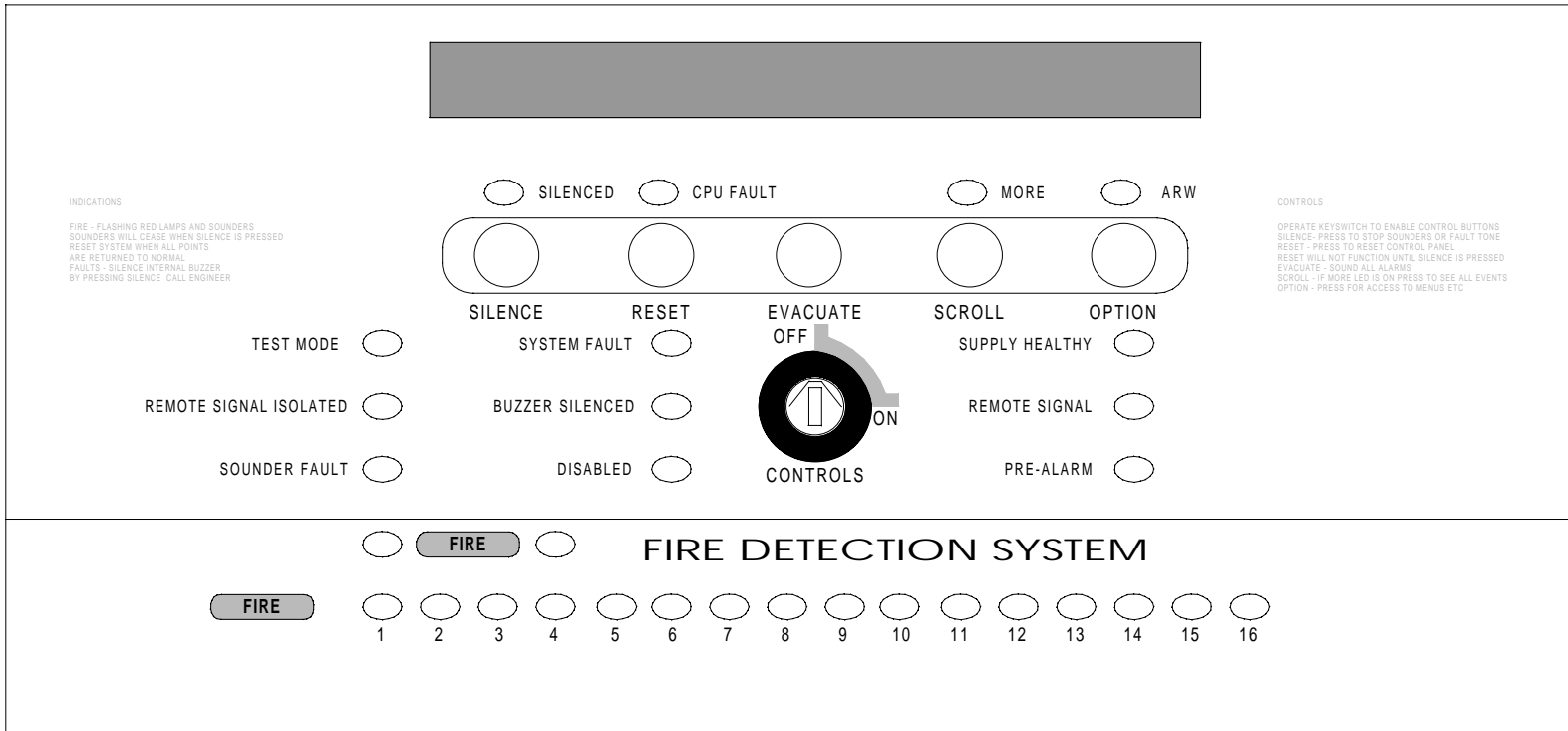

Figure 1 - Control Panel Fascia Layout



# LCD Display

---

The LCD displays event information, status information, and the option menus. It has two lines of text, each with 40 characters, and is backlit when there is an active event on the system or the menu options are accessed.

In the normal operating mode the backlight is off and the top line displays a default text message or user-defined text. The second line displays the current time and date, e.g.

```
Single Loop Addressable Panel
09:36 15/01/97
```

When an event occurs, the backlight is activated and the LCD shows the event details, e.g.

```
Fire           Z003   A002   MAN   1 (Fires)
GROUND FLOOR BY PHOTOCOPIER
```

The display shows the event type, i.e. Fire, the zone that the activated device is in, i.e. zone 3, the address number of the activated device, i.e. 002, the device type, i.e. manual call point, and the number of events, i.e. 1.

**NOTE:** Fault conditions on the system are suppressed when Fire events are present. The SYSTEM FAULT LED is illuminated and faults can be viewed if required via the 'View Active Faults' option - see page 37.

The bottom line displays a text message describing the device location.

In the engineering mode, menu options are displayed as follows:

```
Options Menu
5 - Set Time & Date
```

The control buttons are used to navigate through the menu options and select functions as described later.

# Access Levels

---

To prevent unauthorised operation of the panel controls and functions, access is restricted in accordance with the requirements of BS 5839 : Part 4: 1988 and EN54-2.

The following access levels apply:

Level 1	No restrictions	There are no functions available at this level
Level 2	CONTROL keyswitch ON	The control switches are operable and limited menu functions available
Level 3	Access code	An access code must be entered to gain access to the configuration and advanced options
Level 4	Configuration software	Download facilities are available for off-site programming.

**NOTE:** Amending the system configuration can have serious effects on the operation of the system and should only be undertaken by a competent person who has information concerning the devices installed and the specified operational requirements.

The system should be fully tested after any alterations to the configuration program.

# Main PCB

---

## General

There are two major components of the control panel; the display PCB located on the front door of the unit and the main PCB mounted in the cabinet. External wiring connections, system and configuration software, fuses, function switches, etc are on the main PCB. The following is a list of the main features which are of interest to the installer; a more detailed explanation of each feature is given in the commissioning section.

Refer to figure 2 on page 10 for location.

## Features

1	In and out loop connections		
2	Sounder circuits 1 and 2		
3	Common fire voltfree contacts		
4	Remote signal voltfree contacts		
5	Common fault voltfree contacts		
6	RS 485 for Repeaters and Network		
7	Remote outputs (0V)	SCF	Common fire (silenceable)
		REM	Remote signal (isolateable)
		CFLT	Common fault
		PA	Pre-alarm
		RS	Reset
		CFR	Common fire (non-silenceable)
8	Remote inputs (0V)	E	Evacuate (latching)
		S	Silence
		R	Reset
		P	Precinct (sounders)
9	Auxiliary 12V and 28V supplies		
10	28V remote supply input		
11	Remote charger fault and battery fault input		
12	Battery connection		
13	Clear ARW pushbutton		
14	CPU Reset button		
15	Configuration switch	1	Download
		2	Initialise
		3	Clock battery
16	Clock Trim		
17	EEPROM (Configuration software)		
18	Loop healthy LED (green)		
19	Loop fault LED (amber)		

20	Fuse F6		1A Sounder circuit 1
21	Fuse F7	1A	Sounder circuit 2
22	Fuse F12	1A	Common fire output
23	Fuse F13	1A	Remote signal output
24	Fuse F14	500mA	Auxiliary supply
25	Fuse F2	3A	Supply
26	Fuse F1	5A	Battery
27	Fuse F3	5A	Remote Supply
28	Battery Start Switch		(for starting the system if the main supply is unavailable)
29	Supplies for local printer		

# Main PCB layout

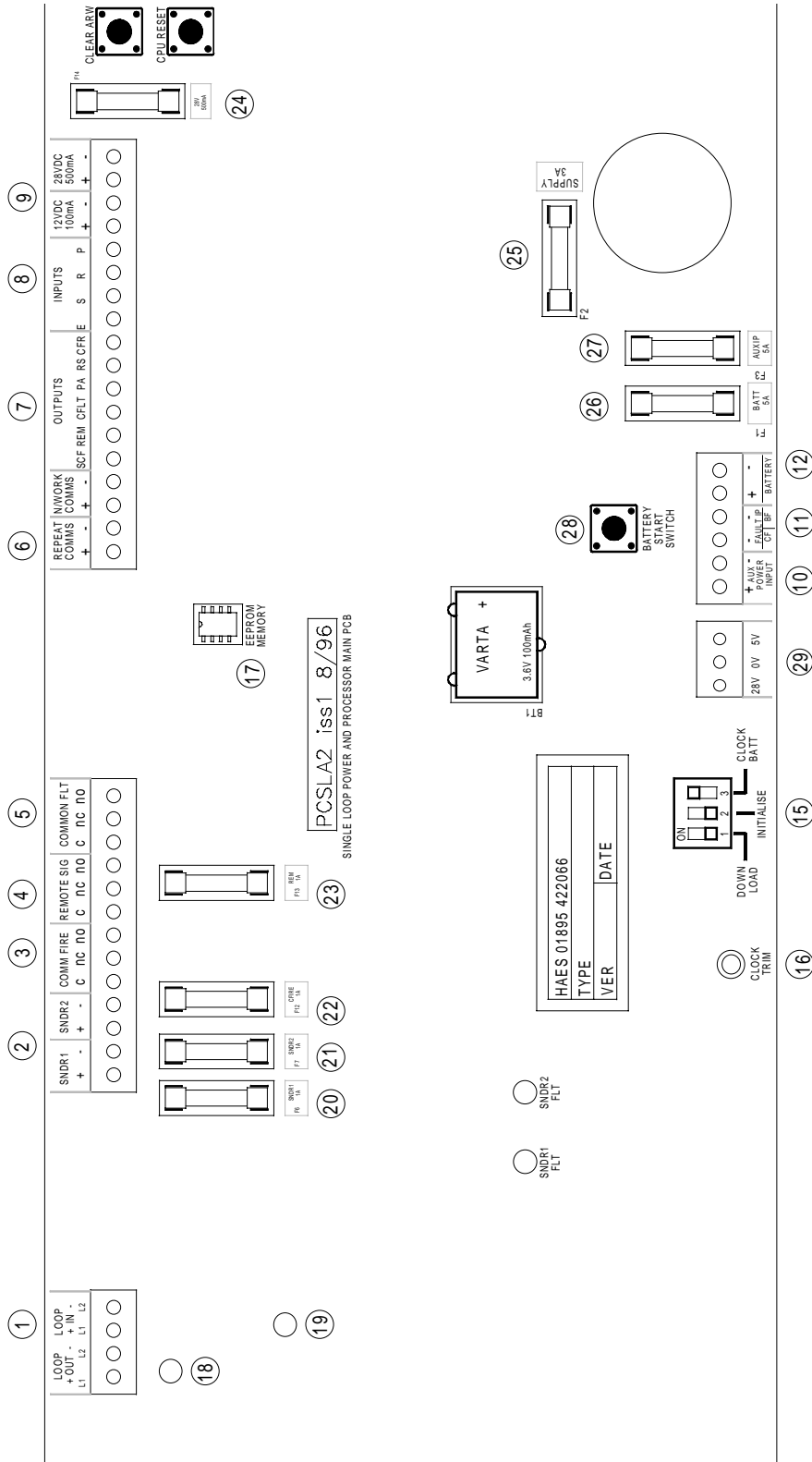

Figure 2 - Main PCB

# Installation

---

## Important - Read this section first!

### **Safety**

Suppliers of articles for use at work are required under section 6 of the Health and Safety at Work Act 1974 to ensure as reasonably as is practical that the article will be safe and without risk to health when properly used.

An article is not regarded as properly used if it is used "without regard to any relevant information or advice" relating to its use made available by the supplier.

This product should be installed, commissioned and maintained by, or under the supervision of, competent persons according to good engineering practice and:

- (i) IEE regulations for the electrical equipment in buildings
- (ii) Codes of Practice
- (iii) Statutory requirements
- (iv) Any instructions specifically advised by the manufacturer

According to the provisions of the Act you are therefore requested to take such steps as are necessary to ensure that any appropriate information about this product is made available by you to anyone concerned with its use.

This equipment is designed to be operated from 220-240V AC mains supplies and is of class I construction. As such it **must** be connected to a protective earthing conductor in the fixed wiring of the installation.

Failure to ensure that all conductive accessible parts of this equipment are adequately bonded to the protective earth will render the equipment unsafe.

### **General**

Installation of the panel should only be carried out by qualified personnel. The electronic components within the panel can be damaged by static charge. Suitable precautions must be taken when handling circuit boards. **Never** insert or remove boards or components, or connect cables, with power on.

## ***Mounting the Cabinet***

The site chosen for the location of the panel should be clean and dry, and not subject to shock or vibration. The temperature should be in the range 5 to 35°C, and the humidity should not exceed 95%.

Remove knockouts required for top cable entry before mounting panel.

Using the cabinet as a template, mark the position of the two keyhole fixings, ensuring that the wall is flat at the chosen location. Drill and plug the wall and insert the screws. Hang the panel on the screws and mark the position of the two lower fixings. Remove the panel and drill and plug the wall. Finally, re-hang the panel and secure with all four fixings.

## ***Cabling***

Suitable cables should be brought into the cabinet using the knockouts provided or the rear cutouts, making sure that tails are long enough to reach the relevant terminals.

The screen or drain wire of loop circuits should be bonded to earth at one location only, and should be continuous throughout the circuit. Drain wires should be terminated in the cabinet as near as possible to the entry point.

Terminals will accept one single or stranded conductor up to 2.5mm<sup>2</sup>.

## ***Power Supply***

The panel requires a 220-240V AC supply which should be derived from a suitably labelled, dedicated isolator.

## ***Field Devices***

Sensors, call points and input/output devices are supplied with full installation instructions. High voltage testing of the wiring must be carried out **before** any devices are connected.

# Commissioning

---

## General

When the control panel is installed and the wiring is complete the system can be commissioned. The commissioning procedure comprises two main elements, (i) connecting the external wiring circuits and powering the panel, (ii) configuring the system for the required operation.

## Field devices

The control panel operates with the Nittan - AS protocol and accepts a range of Nittan field devices. Field devices should be connected to the loop circuit in accordance with the instructions supplied with them, ensuring that where necessary a 24V DC supply is available, and monitoring resistors are fitted. The control panel supports the following devices and uses the type codes indicated:

<b>Code</b>	<b>Device</b>	<b>Part no. (Nittan)</b>
MAN	Manual call point	ST - NCP - AS
ION	Ionisation detector	ST - I - AS
OPT	Optical detector	ST - P - AS
TEM	Heat detector	ST - H - AS
ALM	Sounder module	SCM - AS
ALM	Addressable sounder (with cap)	
ALM	Addressable sounder only	
ZMU	Switch monitor	NAM - AS - BX
ZMU	Zone monitor unit	MCM - AS2
MAN	Switch monitor with interrupt	
RIO	1 Channel I/O unit	MCM - AS2
RIO	Output unit only	OCM - AS
	Short circuit isolator	SCI - 2

## Device address

Each device on the system (excluding short circuit isolators) must have a unique address in the range 1 to 167. All devices are addressed by means of a DIL switch. Devices do not have to be addressed in the order in which they are wired, but there must not be two addresses the same. The control panel will indicate duplicate addresses when powered up and initialised.



## Loop wiring

The loop wiring should be tested in accordance with the requirements of BS 5839 Part 1 before connecting devices.

When the detector bases and other field devices have been connected, the loop should be checked for continuity and earth faults using a multimeter only. To measure the continuity it is necessary to link the L1 IN and L1 OUT terminals in each isolator.

**NOTE:** All Nittan devices are polarity sensitive and must be connected correctly.

Measure the resistance of the loop and ensure that it does not exceed 50 ohms. Check there are no earth faults present.

When the loop wiring checks have been satisfactorily completed, reinstate the isolators and connect the circuit as indicated in figure 3.

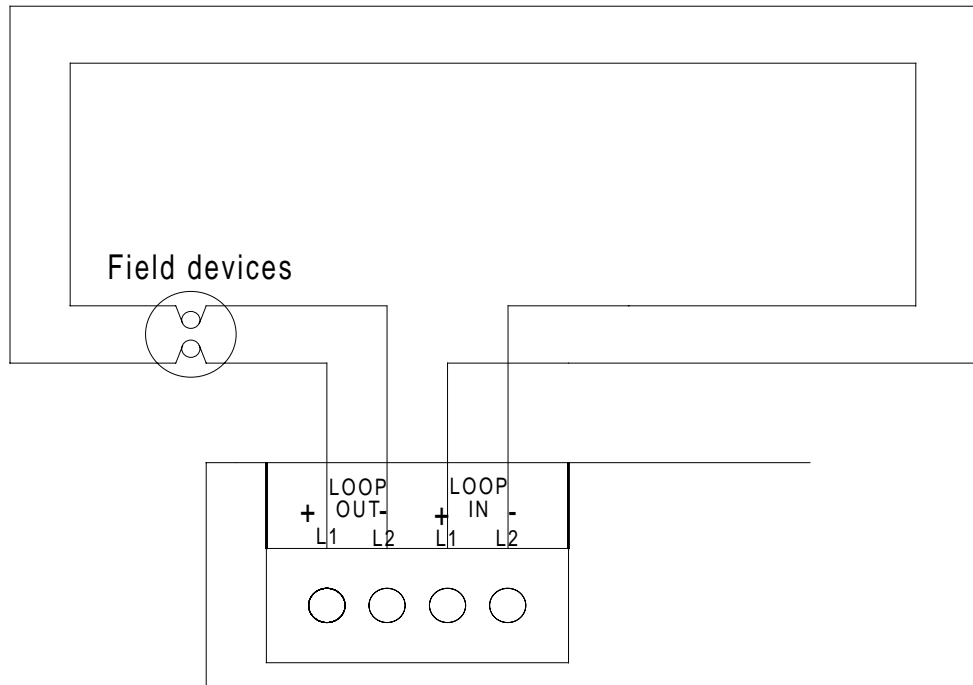

Figure 3 - Loop circuit connection detail

## Powering the panel

It is recommended that following the connection of the loop circuit the panel is powered up and tested before proceeding with the connection of the sounders, remote outputs and auxiliaries.

When the panel is first powered up, the panel must be initialised, or a configuration program downloaded. The loop is scanned and the devices are identified. Each device is displayed showing its address and type, and the zone as 'unassigned', allowing the operator to allocate each device to the required zone (see Initialisation).

## Mains connection

Remove the fuse from the mains terminal block and connect the incoming live, neutral and earth wires to the L, N and E terminals.

Switch on the supply (do not replace the fuse at this stage).

NOTE: If a mains supply is not available, the system can be operated via the battery supply - see 'Starting the panel on battery power' on page 16.

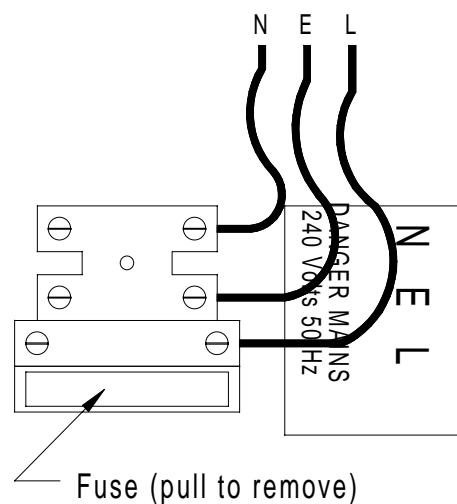

Figure 4 - Main supply connection detail

## ***Connecting the battery***

Prepare to connect the battery as indicated in figure 5 (do not connect the battery at this stage).

**NOTE.** There is a 30 second default delay on the indication of a battery fault when the battery is disconnected. Similarly, when the battery is reconnected, the fault continues to be indicated for 30 seconds.

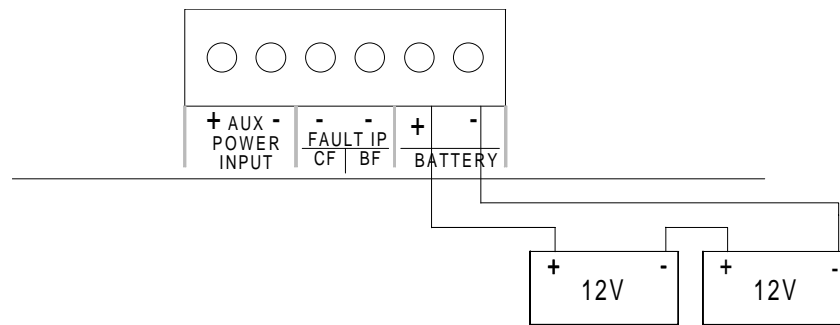

Figure 5 - Battery connection detail

## ***Starting the panel on battery power***

If it is necessary to start the panel without the mains supply, e.g. during commissioning if the supply is not yet available, the 'Battery Start' switch on the main PCB (see figure 2) must be operated for 10-15 seconds following connection of the battery to allow the panel to power up.

A 'Mains fault' is indicated and the buzzer pulses. The buzzer can be silenced by pressing the SILENCE button with the CONTROLS switch ON.

The fault clears automatically when the supply is restored.

## Initialisation

Put the **Initialise** switch (2) to the ON position (up)

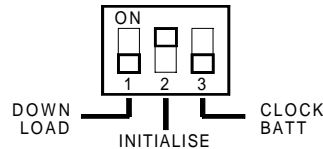

Figure 6 - Initialisation switch  
(see figure 2 for location on main PCB)

Replace the mains fuse and connect the battery. The panel will power up and display the following:

```
Initialisation mode
Enter access code 000
```

### Manual Initialisation

The default access code is 111. Press SCROLL to increment the number and then OPTION to move to the next digit.

Press RESET to enter the code.

```
Initialisation mode
Address 001 TEM Zone *** Unassigned Normal
```

The type code (e.g. TEM) is the device found by the panel at the address and cannot be edited.

The device is assigned to the required zone by pressing SCROLL until the relevant zone number is displayed.

Press OPTION to move to the next address and assign the zone as before by pressing SCROLL. The panel automatically scrolls addresses with no devices and displays the following:

```
Initialisation mode
Address 054 *** Unassigned No response
```

The auto scroll continues until a device is found, or address 126 is reached where the following is displayed:

```
Initialisation mode
Update novram? SCROLL=yes, RESET=no
```

Press SCROLL to enter the data, or RESET to abort the operation.

### Auto Initialisation

This option automatically recognises loop devices and assigns them to zone 1, and can be used during commissioning as a quick method of identifying devices.

To implement this option enter access code 112 at the prompt.

Turn the **Initialisation** switch OFF on completion of either manual or auto initialisation.

These procedures ensure that all addressed devices on the system are recognised and entered into the panel's memory. It is not critical at this stage if the zone assignments are not final as the program can be edited later (see Configuration).

On completion of initialisation a warning message is given thus:

```
N.B. NITTAN MOD DEVICES DEFAULT TO MAN
PROGRAM ALM, RIO AND ZMU DEVICES MANUALLY
```

Press Reset to clear this message.

It is important for correct operation that all devices of type '0', i.e. NCP, NAM, SCM, OCM are correctly specified as types in the configuration of the panel. Refer to page 13 for correct code types.

Sounder controllers and input/output modules can be assigned to special groups Alarms, Contacts or Inputs, depending on the operation required (see Configuration).

An alternative procedure for starting the panel is to fit a pre-programmed EEPROM before applying power, in which case the panel checks that the program agrees with the installed devices and displays any discrepancies (see PC Configuration).

Before proceeding with the connection of other external wiring circuits, turn off the mains supply and disconnect the battery.

## Clock battery

Check that the Clock Battery switch is in the ON position. The panel is supplied with the clock battery OFF to prolong battery life during storage prior to installation and commissioning. See figure 6 for detail of switch.

## Sounder circuits

The two sounder circuits are connected as follows:

**NOTE:** To comply with BS 5839 Part 1, both circuits should be utilised.

Remove the 4K7 resistor from the sounder circuit terminals on the main PCB and fit to the last device on each circuit.

Circuits are fused at 1A each.

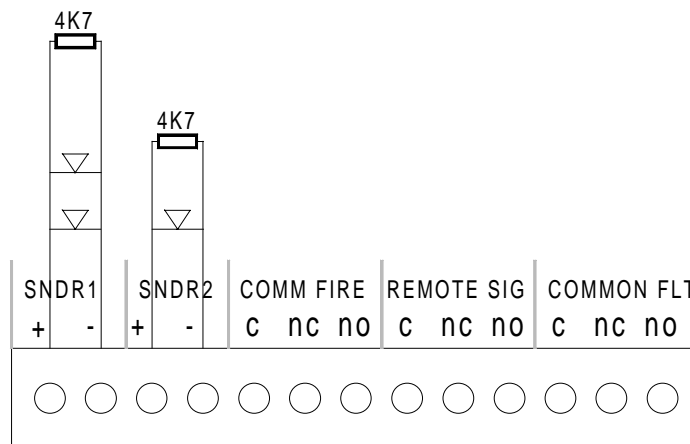

Figure 7 - Sounder circuit connection detail

## Remote contacts

Three voltfree changeover contacts are available for remote signalling or control functions, see figure 7.

Common Fire	Energises on a fire alarm and de-energises on <b>Silence</b>
Remote Signal	Energises on a fire alarm and de-energises on <b>Reset</b> (Can be isolated for system testing)
Common Fault	Energises on any fault condition and stays energised until the fault is cleared.

**NOTE:** Fault relay is normally energised when the system is healthy.

## Remote outputs

The remote output terminals provide a switched 0V supply in conjunction with system events and can be used for control and/or signalling purposes. The load applied to any remote output should not exceed 100mA.

The following outputs are available and are switched on when the relevant event occurs:

- SCF Common fire (switched off when **Silence** is pressed)
- REM Remote signal (switched off when **Reset** is pressed)
- CFT Common fault (switched off when fault clears)
- PA Pre-alarm (switched off when condition clears)
- RS Reset (3 second pulse when **Reset** is pressed)
- CFR Common fire (switched off when **Reset** is pressed)

See figure 8 for location on main PCB.

## Remote inputs

The remote inputs provide control functions from remote switches and are energised by applying 0V via a switch or relay contact.

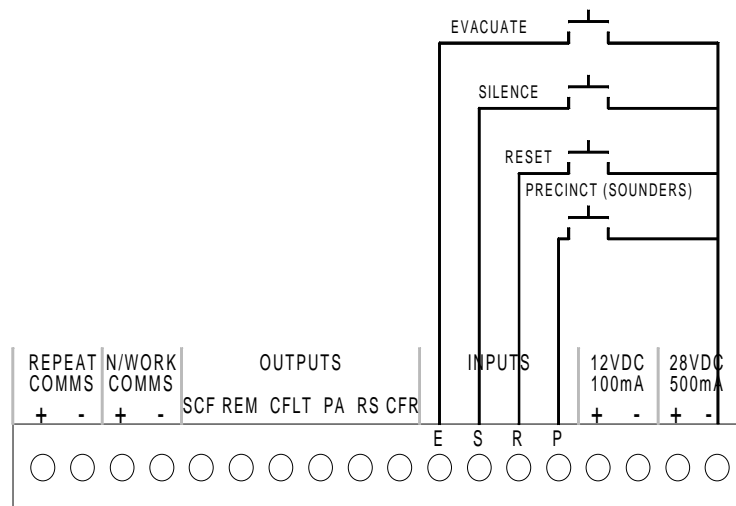

Figure 8 - Remote input connection detail

### Optional zonal outputs

Switched 0V zonal outputs (16) can be provided by fitting the optional PC1007 PCB which connects to a socket on the display PCB. Typical usage is for 'conventional' repeat indication.

Consult the supplier for details.

### Remote power supply

If required, the supply to the control panel can be derived from a remote power supply and battery unit. Input terminals are provided in the control panel for the 28V supply, and charger and battery fault conditions.

**NOTE:** To comply with EN54-2, it is necessary to fit a standby battery within the control panel to provide a one hour standby supply should the remote supply be lost.

In the event of remote supply failure the LCD shows 'Power Supply Fault'.

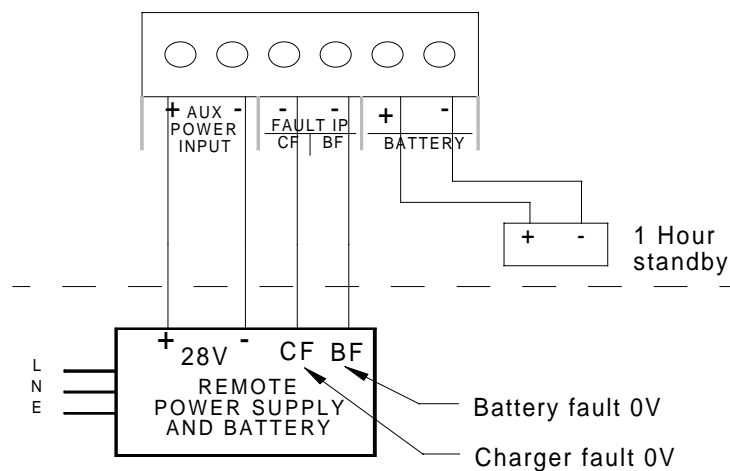

Figure 9 - Remote power supply connection detail



### ***CPU Reset***

The 'CPU Reset' pushbutton on the main PCB (see figure 2) is provided to manually restart the system following the failure of the software to execute a command. The effect is the same as disconnecting and reconnecting power to the panel.

### ***Checking the system***

Any fault conditions indicated at this stage should be investigated and cleared before proceeding with the configuration.

Check that the system operates in accordance with the operation described in the following pages.

### ***Clear ARW***

On initial power-up of the control panel an 'ARW' (Automatic Reset Warning) indication is present. This must be cleared by operating the CLEAR ARW switch on the main PCB (refer to diagram on page 10).

If ARW warnings occur during normal system operation, there may be 'interference' or a software problem.

# Operation - Fire Alarm

---

## **Normal**

During normal operation the only active indication on the control panel is the green Supply Healthy LED. The LCD shows the system normal message and the time and date, and the backlight is off.

The control keyswitch should be in the OFF position and the key should be removed and stored in a secure place, readily available when required.

## **Fire Alarm**

If a manual call point is activated, or an automatic detector senses smoke or heat, a fire alarm signal is generated and the following occurs:

- 1 The alarm sounders operate in accordance with the programmed configuration. This is normally a general evacuation (continuous) alarm throughout the building, but may be an alert (intermittent) signal, or alarm in certain parts of the building only.
- 2 The two common **FIRE** LEDs flash.
- 3 The relevant zone LED flashes (1-16).
- 4 The LCD illuminates and shows the event information.
- 5 The internal buzzer pulses rapidly.
- 6 The remote contacts operate and signal the fire brigade (if applicable).
- 7 Remote control functions are initiated in accordance with the program, e.g. doors closed, ventilation shutdown, etc.
- 8 Event details are printed (assuming a printer is fitted)

The actions to be taken in the event of a fire alarm should be fully documented and implemented immediately upon hearing the alarm.

After the event, the following actions are required to restore the system to normal operation:

First note the event details, i.e. the activated zone and the device details if not already determined.

## ***Silencing the alarm***

Before the alarm sounders can be silenced, or any other control function activated, the CONTROLS keyswitch must be set to the ON position by inserting the key and turning it clockwise a quarter of a turn.

With the controls enabled press the SILENCE button once:

- 1 The alarm sounders on the system are silenced.
- 2 The Silenced LED illuminates to indicate the current status.
- 3 The flashing common fire and zone LEDs go steady.
- 4 The buzzer tone changes to an intermittent bleep.
- 5 The LCD continues to show the event information.

**NOTE:** If another device is activated, the sounders are re-energised and the new event information is displayed. Press the Silence button again to accept the event.

If there are multiple events on the system, the information for each event may be viewed by pressing the Scroll button. The MORE LED is illuminated if there are other events. The LCD shows the total number of events.

## ***Resounding the alarm***

If, having silenced the sounders, it is necessary to reactivate them, e.g. because there are still personnel within the building, press the EVACUATE button.

## ***Resetting the system***

To restore the system to normal operation after a fire alarm it is necessary to reset the control panel by pressing the RESET button.

All the LEDs illuminate for 3 -4 seconds (lamptest function) following which the panel reverts to its normal mode.

**NOTE:**

- 1 It is **not** possible to reset the system until the alarms have been silenced.
- 2 The system will not reset if the cause of the alarm is still present, i.e. broken glass in call point or smoke/heat in the vicinity of a detector.

# Operation - General

---

## **Evacuate**

The EVACUATE button may be operated at any time to activate the alarm sounders.

The CONTROLS keyswitch must be in the ON position.

Press the EVACUATE button once:

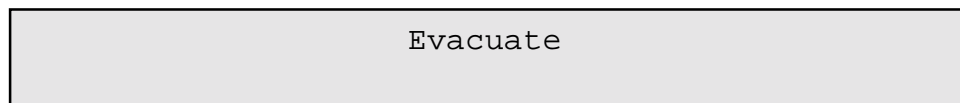

The sounders are energised and the common FIRE LEDs flash.

### **To turn the Evacuate signal off:**

Press the SILENCE button (the Silenced LED illuminates and the flashing fire LEDs go steady).

Press RESET.

## **Panel buzzer**

The internal panel buzzer operates whenever an abnormal event is on the system.

It operates in the following modes:

Fire/Evacuate	Fast pulse
Fault	Slow pulse
Disablement	Double pulse
Silenced	Intermittent bleep

# Operation - Fault

---

## **Monitoring**

The control panel internal circuitry is fully supervised in accordance with the requirements of BS 5839 : Part 4 : 1988 and EN54-2 and indicates a failure as a fault condition. Loop and sounder circuits are monitored for open circuit and short circuit fault conditions. Essential fuses are monitored.

## **Fault condition**

When the control panel detects a fault condition the following occurs:

- 1 The SYSTEM FAULT LED flashes.

**NOTE:** If the fault is on a sounder circuit the SOUNDER FAULT LED flashes also.

- 2 The buzzer pulses (slow pulse)
- 3 The LCD displays the event information, e.g.

No response	Z02	A003	OPT	1(Faults)
GROUND FLOOR RECEPTION AREA				

The fault message is normally self-explanatory, for instance, in the above example the message is 'No response' indicating that the panel cannot communicate with the device (A003), which could indicate that it had been removed. See page 49 for a list of fault messages.

The fault condition can be 'accepted' by pressing the SILENCE button.

The flashing LED/s go steady and the buzzer tone changes to an intermittent bleep.

The panel automatically returns to normal operation when the fault condition clears; however, certain faults, e.g. CPU Fault, require the panel to be reset.

# Panel functions

---

## **General**

The control panel incorporates facilities to alter the status of the system, e.g. it is possible to isolate parts of the system if there is work in progress, or a particular device is faulty and causing unwanted alarms. The system can be put into test mode to allow an engineer to activate devices without causing a general alarm, and the time and date can be changed, e.g. for British Summer Time.

These functions are accessible to the user at access level 2 but care should be exercised when utilising the functions as it is possible to disable some or all of the system. It is recommended that before attempting to enter the options menu the features are fully understood, and the operator is familiar with the controls used to navigate the menus and select options.

## **Function buttons**

**Three** of the control buttons are used as function buttons when the options menu is invoked. All of the panel functions, including configuration, are controlled by these buttons which have the following functions:

<b>OPTION</b>	The Option button is used to initially invoke the options menu and thereafter to scroll the menu options and sub-menu options
<b>SCROLL</b>	The Scroll button is used to edit data within a menu option, e.g. changing the hour and minute values in the clock setting option.
<b>RESET</b>	The Reset button is used to select a menu item from the options menu and, following editing, to enter the new data.

The Reset button also reverts the display to the main menu if it is necessary to escape from the current menu option.

## **Level 2 Options menu**

- 1 Enable/disable Remote Outputs
- 2 Enable/disable Zones
- 3 Enable/disable Addresses
- 4 Disable Sounders
- 5 Set Time and Date
- 6 View Active Disablements
- 7 View Active Faults
- 8 Zone Test
- 9 Change Access Level
- 10 Quit Menu

# Menu Option procedures

---

The following procedures are common to all of the menu options and should be understood before attempting to alter the system status.

To access the Options Menu the CONTROLS key switch must be in the ON position.

Press the OPTION button to display the following:

```
Elite 1 Fire Alarm System
Options Menu
```

Press RESET to access the Options menu.

```
Options Menu
1 - Enable/disable remote outputs
```

Use the OPTION button to scroll through the options. It is only possible to scroll in one direction, therefore if you scroll past the required option you must continue to scroll until it appears again.

When the required option is displayed, press the RESET button.

Depending on the option selected, there may be sub-menu items which are accessed by pressing the OPTION button again. Press RESET to select the option required.

To change the current information the SCROLL button is used. Where there are several items to be edited, the program defaults to the first item which can then be edited with the SCROLL button. Pressing the OPTION button moves to the next item to be edited, and so on.

When you are satisfied with the data, press RESET to confirm the instruction.

The display reverts to the Exit option (10). Press RESET to exit, or turn the CONTROLS key OFF.

The display reverts to normal and the new instructions are implement, i.e. if part of the system has been disabled the DISABLED LED is illuminated and the buzzer emits an intermittent double pulse.

The panel remains in this condition until the function is either manually reset or the auto-reset cancels the function (see Auto enablement).

# Enable/disable remote outputs

---

## *Manual*

Isolates the remote output, and loop output relay modules, for system testing, etc.

Press the OPTION button to display the first option, i.e.

```
Options Menu
1 - Enable/disable remote outputs
```

Press RESET

```
1 - Enable/disable remote outputs
Manual enablement selected
```

Press RESET

```
1 - Enable/disable remote outputs
Remote outputs enabled
```

Press SCROLL to toggle enabled/disabled

```
1 - Enable/disable remote outputs
Remote outputs disabled
```

Press RESET

```
Options Menu
10 - Exit
```

Press RESET.

The display reverts to normal. The DISABLED LED is illuminated and the buzzer sounds until the remote outputs are enabled by repeating the above procedure.

To enable the outputs automatically, use the Auto-enable feature (see page 30).



## **Auto enablement**

Automatically cancels the disablement at a pre-set time and date. The output can initially be manually disabled as described on page 29 before setting the auto enable.

Display the following option as previously:

```
1 - Enable/disable remote outputs
Manual enablement selected
```

Press OPTION

```
1 - Enable/disable remote outputs
Auto enablement selected
```

Press RESET

```
1 - Enable/disable remote outputs
Auto enable at 00:00 00/00/00
```

Press SCROLL to advance the hours to the required setting (it is not possible to scroll backwards).

Press OPTION to move to the minutes, press SCROLL to advance the minutes to the required setting.

Continue to edit the date setting using the SCROLL and OPTION buttons. When the required value is displayed, press RESET.

```
Options Menu
10 - Exit
```

Press RESET.

The display reverts to normal. The DISABLED LED is illuminated and the buzzer sounds until the remote outputs are enabled at the designated time and date.

To enable the outputs manually, repeat procedure on page 29.

# Enable/disable zones

---

## Manual

This function allows a zone to be disabled.

Press OPTION until the zone option is displayed

```
Options Menu
2 - Enable/disable zones
```

Press RESET

```
2 - Enable/disable zones
Manual enablement selected
```

Press RESET

```
2 - Enable/disable zones
Zone 1 enabled
```

Press OPTION to change the zone number, and SCROLL to toggle enable/disable.

When the required zone indicates 'disabled', press RESET

```
Options Menu
10 - Exit
```

Press RESET.

The display reverts to normal. The DISABLED LED is illuminated and the buzzer sounds until the zone is enabled by repeating the above procedure.

To enable the zone automatically, use the Auto-enable feature (see page 32).

**NOTE:** Disabling a zone inhibits the alarm input and fault monitoring of field devices, but does not prevent their programmed response occurring, e.g. sounder modules in an isolated zone will respond to a programmed input from a device in a normal (not isolated) zone.

## Auto enablement

Automatically cancels the disablement at a pre-set time and date. The zone can initially be manually disabled as described on page 31 before setting the auto enable.

Display the following option as previously:

```
2 - Enable/disable zones
Manual enablement selected
```

Press OPTION

```
2 - Enable/disable zones
Auto enablement selected
```

Press RESET

```
2 - Enable/disable zones
Auto enable at 00:00 00/00/00
```

Press SCROLL to advance the hours to the required setting (it is not possible to scroll backwards).

Press OPTION to move to the minutes, press SCROLL to advance the minutes to the required setting.

Continue to edit the date setting using the SCROLL and OPTION buttons. When the required value is displayed, press RESET.

```
Options Menu
10 - Exit
```

Press RESET.

The display reverts to normal. The DISABLED LED is illuminated and the buzzer sounds until the zone is enabled at the designated time and date.

To enable the zone manually, repeat procedure on page 31.

**NOTE:** All disabled zones are enabled at the auto-enablement time, regardless of when set.

# Enable/disable address

---

## *Individual device isolation*

This function allows a selected device to be disabled.

Display the following option.

```
Options Menu
3 - Enable/disable address
```

Press RESET

```
3 - Enable/disable address
Address 001 TEM enabled
```

Press OPTION to change address, and SCROLL to toggle enable/disable.

**NOTE:** The device type, e.g. TEM (heat detector) is shown by default.

When the required address shows disabled, Press RESET

```
Options Menu
10 - Exit
```

Press RESET.

The display reverts to normal. The DISABLED LED is illuminated and the buzzer sounds until the address is enabled by repeating the procedure.

**NOTE:** Disabling a device only affects its input function and not its output function (if any).

## Disable sounders

---

Allows the panel alarm sounders and loop sounders to be isolated if required.

Display the following option:

```
Options Menu
4 - Disable sounders
```

Press RESET

```
4 - Disable sounders
Sounders enabled
```

Press SCROLL to toggle enabled/disabled, and press RESET

```
Options Menu
10 - Exit
```

Press RESET.

The display reverts to normal. The DISABLED LED is illuminated and the buzzer sounds until the sounders are enabled by repeating the procedure.

## Set time and date

---

Allows the time and date to be adjusted, or amended for British Summer Time.

Display the following option:

```
Options Menu
5 - Set Time & Date
```

Press RESET

```
5 - Set Time & Date
Scroll=Set, Options=Next 08:42 16/01/97
```

A flashing cursor indicates the currently selected digit. Press SCROLL to change the value, and OPTION to move to the next digit/character.

When the correct time and date is displayed, press RESET.

```
Options Menu
10 - Exit
```

Press RESET.

The display reverts to normal with the new time and date displayed.

## View active disablements

---

This facility allows parts of the system that have been isolated to be identified.

Display the following option:

```
Options Menu
6 - View active disablements
```

Press RESET

```
Zonal Disablements
No disabled zones
```

or

```
Zonal Disablements
Zone 01
```

Similar information is provided for remote outputs and addresses by pressing OPTION.

Press RESET to exit and return to the main menu.

```
Options Menu
10 - Exit
```

Press RESET.

The display reverts to normal.

## View Active Faults

---

This option provides a method of viewing faults on the system when there are active fire events present.

Display the following option:

```
Options Menu
7 - View Active Faults
```

Press RESET

```
View active faults
No fault found
```

or

```
View active faults
No response Z02 A004 OPT
```

Press OPTION to scroll the active faults.

Press RESET to exit and return to the main menu.

```
Options Menu
10 - Exit
```

Press RESET.

The display reverts to normal.



# Zone Test

---

Zone test (walktest) is an engineering function to enable the devices (detectors, call points, etc) to be tested without generating a full alarm, and without the need to reset the system after each activation.

Display the following option:

```
Options Menu
8 - Zone test
```

Press RESET

```
Zone test
With sounders
```

Press OPTION to toggle With sounders/Without sounders.

When the required option is displayed, press RESET.

```
Zone 01 in test mode
```

Press SCROLL until the required zone to be tested is displayed.

The selected zone is now in test mode.

Devices assigned to the selected zone can be activated and will automatically reset after a few seconds. Detector LEDs illuminate to indicate the device operation.

The device address and type is displayed.

If the 'With sounders' option is selected, the alarm sounders operate for 2-3 seconds each time a device is activated (see Configuration for operation of devices assigned to Alarms, Contacts or Inputs).

Press RESET to exit and return to the main menu.

Press RESET. The display reverts to normal.

**NOTE:** Loop sounders and/or modules may remain energised for extended periods of time due to protocol requirements.

# Change Access Level

---

This option enables the level 3 menus to be accessed and requires a code to be entered before access is permitted.

Display the following option:

```
Options Menu
9 - Change access level
```

Press RESET

```
Options Menu
Enter access code 000
```

The default access code is **195**. Press SCROLL to increment the first digit and then OPTION to move to the second digit. Continue to enter the code using SCROLL and OPTION until 195 is displayed.

Press RESET.

```
13 - Repeaters on line
```

The following menu options are offered at access level 3:

- 11 View/edit device configuration - refer to page 54  
(Initialise switch must be 'on' )
- 12 Select heat sensor grades
- 13 Repeaters on line
- 14 Examine event store
- 15 Print event store
- 16 Clear event store
- 17 Print loop status
- 18 Transmission test mode
- 19 Maintenance check
- 20 Edit group type/Default ring mode - refer to page 56  
(Initialise switch must be 'on')
- 21 Exit.

## Select heat sensor grades

---

This option allows selection of three heat sensor grades of response. The grades are selected for three address bands allowing different responses to be obtained depending on which band the heat sensor's address is located.

**Note:** All heat sensors in an address band are affected. Consideration must be given to the addressing of all heat sensors for required responses.

The grades are:

- Grade 1 = 58 degrees C
- Grade 2 = 66 degrees C
- Grade 3 = 74 degrees C

To access this menu the 'Initialise' switch must be 'ON'. To select heat sensor grades display the following option:

```
12 - Select heat sensor grades
```

Press RESET

```
Select heat sensor thresholds  
Addresses 1 - 50 = Grade 1
```

Press SCROLL to adjust threshold (Grade 1, 2 or 3).

Press OPTION to select range of addresses (1 to 50, 51 to 100, 101 to 167).

Press RESET to exit.

## Repeaters on line

---

This feature is provided to monitor repeater units connected to the system. Each repeater has a unique address in the range 0 to 7, i.e. a maximum of eight repeaters may be installed. Repeater 1 is address 0, repeater 2 address 1, etc. Repeater addresses must be set sequentially.

To set the quantity of repeaters, display the following option:

```
13 - Repeaters on line
```

Press RESET.

```
Enter number of repeaters 00
```

Press SCROLL to set the number of repeaters on line.

Press RESET to accept the quantity set.

Press the OPTION button until the Exit option is displayed, and then press RESET.

The display reverts to level 2 menu options.

The panel attempts to communicate with the programmed repeaters and will indicate a fault if they are not found.

## Examine event store

---

This option enables the panel's event log to be viewed.

Display the following option:

```
14 - Examine event store
```

Press RESET to view events, e.g.

```
Sounder 2 open  
10:59 17/11/97
```

The most recent event is displayed with the time and date of the occurrence.

Press OPTION to view events in reverse chronological order.

Press RESET to exit.

Press the OPTION button until the Exit option is displayed, and then press RESET.

The display reverts to level 2 menu options.

## Print event store

---

This option transfers the contents of the event store to the panel printer (if fitted).

Display the following option:



15 - Print event store

Press RESET to start printing.

Press RESET to exit and stop printing at any time.

Press the OPTION button until the Exit option is displayed, and then press RESET.

The display reverts to level 2 menu options.

## Clear event store

---

This option enables the event store to be completely erased.

Display the following option:

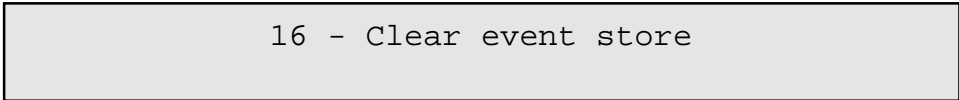

16 - Clear event store

Press RESET to clear the memory.

Press the OPTION button until the Exit option is displayed, and then press RESET.

The display reverts to level 2 menu options.

# Print loop status

This option enables the status of all loop devices to be printed via the panel printer (if fitted).

Display the following option:

17 - Print loop status

Press RESET to start the print-out, e.g:

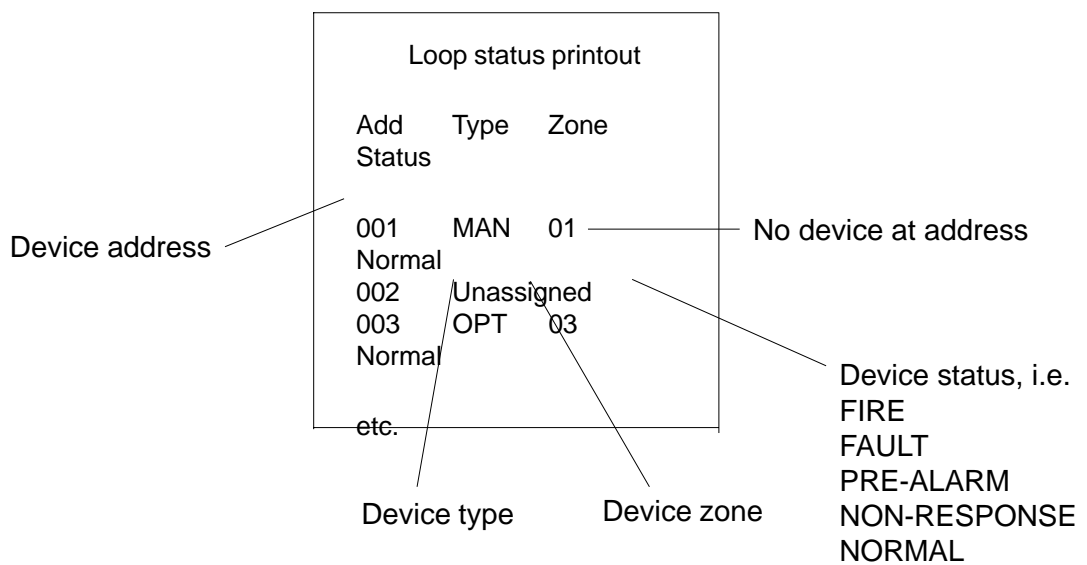

Figure 10 - Typical Printout

Press RESET to exit.

Press the OPTION button until the Exit option is displayed, and then press RESET.

The display reverts to level 2 menu options.



## Transmission test mode

---

This feature allows each address to be polled individually and the data examined.

For each selected device the real time analogue value is displayed and the device LED is illuminated. The illuminated LED can assist in identifying the device where its location is not known, i.e. if the device is one of several in the same area. Furthermore, if there are two devices with the same address, both device LEDs are illuminated and thereby enable the relevant devices to be identified.

The feature can also be used to determine the position of a break in the loop circuit by selecting the 'radial' option - devices beyond the break would be unable to be polled.

**NOTE:** Normal polling is suspended in this mode

Display the following option:

```
18 - Transmission test mode
```

Press RESET, e.g.

```
18 - Transmission test mode
Address 001  MAN  Zone 10  Ana 016
```

The status of each device is shown by the analogue value being displayed in real time. The following values indicate the current device status in hexadecimal values. Values vary according to device type.

Value	Status
0	Device not responding or missing
0 - 4	Device faulty
11- 15	Device normal
12 - 16	Maintenance threshold (device may require cleaning)
15 - 19	Pre-alarm threshold
19 - 1C	Fire threshold

To move to the next address, press the OPTION button. To move to the previous address, press SCROLL.

'R' or 'P' denotes whether radial or parallel polling is selected. Press EVACUATE to make a selection.

Figure 11 indicates the difference between Radial and Parallel polling.

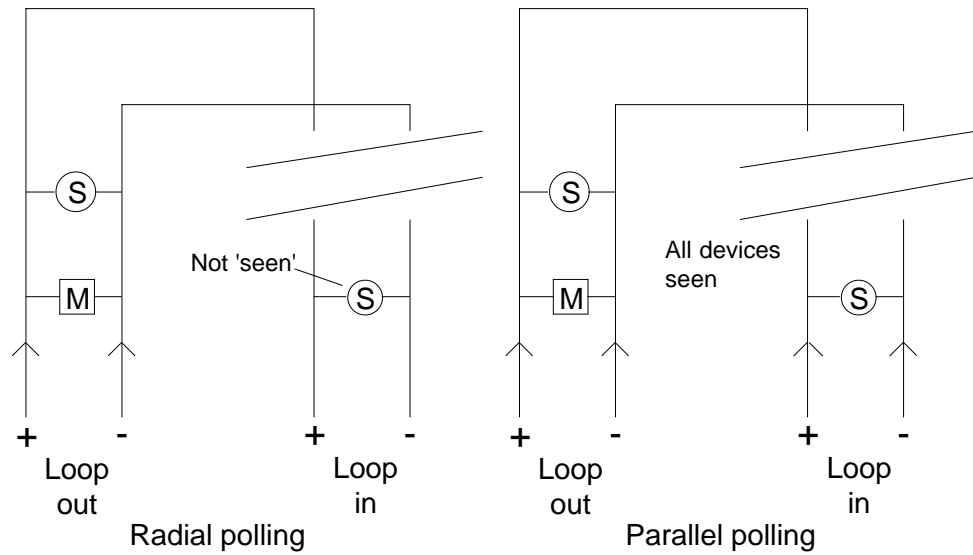

Figure 11 - Polling options

To exit this option and return to the main menu, press RESET.

# Maintenance check

---

Selecting this option prompts the control panel to scroll the loop devices searching for any device returning an analogue value of between 35 and 45, indicating that attention is required. (See pages 46 and 51 for analogue data).

Display the following option:

```
19 - Maintenance check
```

Press RESET. The display scrolls each device automatically until all 167 addresses have been scanned, unless a value between 12 and 16 is detected in which case the scrolling halts and the relevant device data are displayed. A typical display for each address is as follows:

```
Reporting excessive levels  
Address 001 TEM Zone 10 ANA 008
```

or

```
Reporting excessive levels  
Address 051 *** Unassigned ANA 000
```

Press RESET to exit and return to the main menu.

## ***Exit level 3 menus***

To exit the level 3 menu options, select option 21 - Exit and press RESET.

The display reverts to level 2 menu options. To exit, scroll to the exit option (10) and press RESET, or turn CONTROLS off.

The panel reverts to normal operation displaying the time and date.

# Fault messages

---

The following events are detected and reported:

<b>Message</b>	<b>Fault/condition</b>
No response .....	Device removed
Type error .....	Device fault/wrong device type installed
Loop fault .....	Loop circuit open/short circuit
Remote power supply lost .....	Remote PSU failed
Sounder x short/open .....	Open/short circuit on sounder circuit
Mains fault .....	Mains failed
Battery fault .....	Battery disconnected (30s delay)
Earth fault .....	Earth fault
Dual address fault .....	Duplicate address
CPU Fault .....	CPU failed
Novram checksum error .....	Fault in configuration memory
Repeater comms fault .....	Communications failure
Down load switch on .....	Download switch on
Remote PSU mains fail .....	Remote charger fault input active
Remote PSU battery fail .....	Remote battery fault input active
Various .....	Fuse failure (except remote PSU input fuse)

# Configuration

---

## **Introduction**

Following the initialisation procedure, the control panel has basic functionality, i.e. if a detector or call point is activated, the alarm is annunciated and the sounder circuits are energised. For the system to function in any other way it must be configured for the required operation. This configuration is also known as 'cause and effect', i.e. the action in the event of a particular occurrence is specified.

The cause and effect capability of the panel is quite powerful and provides sufficient flexibility to enable the system to be configured for the required operation in most cases. Where there are special requirements which cannot be met by the standard features, it is possible for the software to be customised to satisfy a particular project. The supplier should be consulted in such circumstances. The PC Configuration program is described in a subsequent section.

Of the configuration options available, full editing may be carried out via the panel control switches. Configuration editing, including assigning devices to groups, etc. can also be carried out via the PC software program which is used to program a memory chip that is inserted in the panel.

To provide a better understanding of how the system may be configured, the various device types and their operation is explained in more detail in the following paragraphs.

## **Zones**

The panel is equipped with 16 'fire' zones which are used to indicate the location of a device, or group of devices, on the system. Any device which is required to provide an indication on the panel must be assigned to a fire zone (1 to 16). Applicable devices are detectors (ionisation, optical and heat), call points, and input modules.

In addition to the 16 fire zones, options are available for special functions as follows:

Alarms	Sounder modules (type ALM) on the loop which are assigned to 'Alarms' are activated in an alarm condition and provide a continuous output, i.e. 'general alarm' output.
Contacts	Input/Output modules assigned to 'Contacts' operate on any alarm condition to provide auxiliary contacts for 'general' switching functions.
Inputs	Input/Output modules assigned to 'Inputs', operate the output when the associated input only is active .

## ***Device configuration***

Device types operate and are monitored by data (bits) transmitted to and received from the device. The transmitted bits are used to turn on detector LEDs, module outputs, etc (output bits), and the received bits are used to identify the device type, its address, current status, etc (input bits). For a fuller explanation of the data transmission the Nittan literature should be consulted.

**Devices may be assigned to zones as follows:**

MAN, OPT, ION, TEM	Zones 1 to 16 only
ALM	Zones 1 to 16 and Alarms
RIO	Zones 1 to 16, Contacts or Inputs
ZMU	1 to 16 only

## ***Device types and responses:***

### **Detectors**

MAN, OPT, ION and TEM are general detection devices and are assigned to zones 1 to 16. The manual call point (MAN) has a fast response interrupt facility for rapid operation of sounder outputs.

The data value returned by the devices is generally as follows:

Fault	Less than 04
Normal	Between 06 and 15
Maintenance	Between 16 and 19
Pre-alarm	19 +/- 3
Fire	Greater than 1C

## **ALM - Sounder Control Module/Loop powered sounder**

The sounder module provides a single monitored sounder output, and requires a 24V DC supply and a 10K end-of-line resistor. Up to 30 loop powered sounders can be installed and do not require an additional power supply. Loop sounders are single point devices.

Data values:

Normal	0 - 16
Fault	04 (open and short circuit or power supply fault if monitored)

Output bit operation:

Bit 0	Activates sounder output in continuous mode
Bit 1	Activates sounder output in pulse mode
Bit 2	Not used

Operation:

Modules and loop sounders programmed to a specific zone (1 to 16) operate in zonal response mode, e.g. modules/sounders in the zone of fire activate in continuous mode. Modules/sounders in other zones are silent.

Modules/sounders programmed to Alarms respond as a general alarm, i.e. activate with any input.

ALM devices respond to Evacuate, Silence and Precinct in the same manner as the panel sounder circuits.

## **RIO - Input/output modules**

Single input/output devices.

Data values:

Normal	06 - 16
--------	---------

**NOTE:** No other data is returned from this module type.

Output bit operation: Bit 0 Activates relay output 1

Operation:

Modules programmed to a specific zone (1 to 16) activate in zonal response mode, i.e. module output/s are turned on when the specific zone is active.

Modules programmed to Contacts all operate on any alarm, i.e. general auxiliary contacts.

Modules programmed to Inputs respond as follows:

If a module input is activated, the corresponding output is turned on and the panel displays, e.g.

```
Input 1 Active   Address xxx   Zone 19
PUMP 1 STOPPED
```

There is a fire response, i.e. sounders operated.

#### **ZMU - Zone monitor unit**

This device monitors a zone of conventional fire detection devices and requires a 24V DC supply.

Data value:

Normal	0 - 16
Fault	04 (open and short circuit)
Fire	19

Output bit operation:

Bit 0	Resets the zone
-------	-----------------

Input bit operation:

In engineer's test mode these devices respond as standard devices.



# Panel configuration

---

## Device edit

The panel configuration options enable device types to be edited, devices to be assigned to zones and groups, and location text to be programmed. The data stored during the initialisation procedure may be accurate in which case further configuration may not be necessary. If it is required to edit the current configuration, e.g. if a device type is changed, added or removed, or needs to be allocated to a different zone, then it can be achieved via the panel controls as follows:

Ensure the 'Initialise' switch is on. Access the level 3 menu options, i.e.

```
11 - View/edit device configuration
```

Press RESET

```
Address 001  Zone 10  Type TEM          G ****
TEXT MESSAGE HERE
```

Press OPTION to move the cursor between the Address (100s, 10s, 1s), Zone No., Device Type, Groups, and Message text.

To select an address, position the cursor under the relevant digit using OPTION, and then press SCROLL until the required address is displayed.

Press OPTION to move to the Zone No.

```
Address 005  Zone 12  Type OPT          G ****
TEXT MESSAGE HERE
```

Press SCROLL to change the zone number, and then press RESET when the required zone is displayed.

```
Address 005  Zone 14  Type OPT          G ****
TEXT MESSAGE HERE
```

The Type field is now selected. Press SCROLL until the required device type is displayed.

**NOTE:** The zone and type options have an 'unassigned' option indicated thus \*\*\*, if the device is being removed.

## **Group edit**

Group editing consists of assigning the currently selected device to a group by turning any or all of the four available groups on (or off), and defining the function of each group.

**NOTE:** For an explanation of group functions and examples of their use in system operation, refer to the PC Configuration section page 61.

The 'G' on the display denotes Groups. Groups are numbered 1 to 4 and are indicated by the relevant number when they are on (active), and an asterisk when they are off (inactive).

For example, if Groups 2 and 4 are on, the display would indicate G \*2\*4.

To select a group and turn it on/off, press OPTION until the cursor is below the group to be switched. Press SCROLL to toggle the group on/off. The currently selected device is assigned to all groups that are 'on'.

**NOTE:** Pressing RESET at any location other than Address reverts the cursor to Address. Pressing RESET whilst Address is selected exits the option.

To edit the group function refer to **Edit group type** following Text edit.

## **Text edit**

To create a text message, or to amend an existing message, press the OPTION key to position the cursor on the character to be input/edited.

**NOTE.** It is not possible move to a preceding character, i.e. 'left', therefore continue to press OPTION until the cursor is on the required character if necessary.

To select a character, press SCROLL to scroll up, or EVAC to scroll down, until the desired character is displayed.

Press option to move the cursor to the next position and repeat to select the character. Continue to select and edit characters until the desired message is displayed.

Press RESET to return to the first option and continue to edit other addresses if required.

Press RESET to exit.

## ***Edit Group Type/Default Ring Mode***

Group type editing, i.e. defining the group function is accessed via option 19 of the main menu. This option also enables the default ring mode to be selected; for an explanation of the default ringing mode refer to PC Configuration page 63.

Ensure the 'Initialise' switch is 'on'. Access the level 3 options as described previously and select option 19 - Edit Group Type/Default Ring Mode.

```
Group 1 Normal
```

Press SCROLL to change the group type, i.e. Normal/2 Stage/Coincidence.

Press OPTION to select the next group (2), and press SCROLL to select the group type. Repeat for groups 3 and 4.

After the fourth group has been displayed, a further operation of the SCROLL push-button accesses the ringing mode option, i.e.

```
Default Ring Mode :- Continuous
```

Press SCROLL to toggle 'continuous' and 'pulsing' and select the required option.

Press RESET to exit the option. Turn the Initialise switch 'off'.

# PC Configuration

---

## ***Introduction***

The Elite 1 PC Configuration program enables a system to be programmed to operate in accordance with specific requirements, and includes options for zonal sounder operation, 2-stage and coincidence functions, selective output device operation, etc. The program also enables device types to be programmed, devices to be assigned to zones, and device location text to be entered. In addition, the number of repeaters can be specified, and devices can be assigned to groups.

Configuration file/s are created via the PC program and downloaded to an EEPROM (novram) which is then inserted into the panel.

**NOTE:** Once configuration software has been downloaded to the panel it may no longer be possible to carry out the initialisation procedure, i.e. any modifications to the system must be programmed, either manually at the panel or downloaded from a PC.

The software is supplied on disk and comes complete with a custom device to program the novram.

## ***Before you start***

Inserting a novram containing a configuration program into a panel will affect the way that the panel functions and could result in a system operation that does not comply with British Standards and/or the specification. The fact that there are no faults indicated does not necessarily infer compliance. Therefore, persons using this program should be in possession of the full system information, and should be familiar with the procedures described in this manual before attempting to create or edit a configuration program .

It is assumed that users of the PC Configuration program are experienced fire alarm system engineers with basic computer skills and an understanding of DOS commands.

## ***System requirements (DOS version)***

An IBM compatible PC running DOS 3.x or later, and fitted with a floppy disk drive and parallel printer port is required.

It is recommended that the configuration program is copied from the floppy disk on which it is supplied to the machine's hard disk into a selected directory using standard DOS Copy commands.

A new WIN 95 version is also available, which requires a serial port (see separate manual).

The following file should be copied:

ELITE1.EXE

The program can be run from the floppy disk: however, it is recommended that the master disk is copied and stored securely.

### ***Running the program***

Start the PC and select the drive and directory where the configuration file is located, e.g. C:\CON\> or A:\>.

Type **ELITE1** (or **elite1**) and press ENTER.

The program starts and displays the initial menu.



Figure 12 - Initial menu

To select an option, either use the arrow keys to highlight the required option and press ENTER, or simply press the relevant option number key.

### **Options**

1 Read data from novram

Enables existing data to be uploaded from a novram for viewing and or editing.

2 Read data from file

Enables previously saved data to be uploaded from a diskfile for viewing or editing.

3 Continue

Accesses the edit screen.

## ***Configuration options***

On a new project there are basically two ways of loading the required configuration data into the panel.

If the initialisation procedures described previously are carried out, the novram from the panel can be read into the configuration program and edited as required, e.g. group assignments, etc., by using the 'Read data from novram' option. This method ensures that the device information is correct, i.e. the device type programmed for each address matches the installed device.

Alternatively, a configuration file can be created via the PC program and downloaded to the novram, for insertion in the panel. If this method is chosen the programmer must ensure that the device details entered into the program match the installation.

Newly created or edited files can be saved to disk for record purposes, and the data can be subsequently retrieved for editing and/or downloading to an novram. To retrieve a file from disk, select 'Read data from file' option and follow the on-screen prompts.

The 'Continue' option is selected to display the edit options menu and the edit screen where a configuration program is created or edited before being saved and/or downloaded.

Finally, the configuration file can be printed as a hard copy record of the system program.

## ***Overview of PC Configuration options***

Before creating or editing a configuration file it is important to understand the available options and the program/system limitations. The following paragraphs describe the basic functions of the program and how they affect the system operation when downloaded to the panel novram. The programmer should also be in possession of the device information, i.e. address, type, location, etc., and understand the specified operation.

The available device types and their function are described in the Configuration section earlier in this manual, but are outlined again here for clarification.

The device types are:

Sensors, i.e. Ionisation (ION), Optical (OPT) and Temperature (TEM)  
Manual Call Point (MAN)

Sounder module/Addressable sounder (ALM)  
Input/output module (RIO)  
Zone Monitor (ZMU)

**NOTE.** The device type assigned to each address must match the installed device type.

### **Assigning devices to zones**

Devices which are to be indicated zonally by the panel, i.e. sensors, call points, zone modules and input modules must be assigned to a zone in the range 1 to 16.

ALM device types (sounders) can be assigned to a zone in the range 1 to 16, or to 'Alarms'. See page 50 for an explanation of the 'special' groups.

Sounders assigned to a specific zone operate when a device in the same zone is active. All other sounders are either silent or pulsed, depending on the 'default ringing mode' which is selected in the edit screen.

Sounders assigned to 'Alarms' operate when any device is active, i.e. general alarm, irrespective of the default ringing mode.

Input/output modules (RIO) can be assigned to a zone in the range 1 to 16, or to 'Contacts' or 'Inputs'.

I/O modules assigned to a specific zone turn their output on when a device in the same zone is active.

I/O modules assigned to 'Contacts' turn their output on when any device is active.

I/O modules assigned to 'Inputs' turn their output on when the associated input is active. There is no fire response and no sounders are activated; a text message is displayed and the SYSTEM FAULT LED is illuminated.

#### *Example 1*

In a multi-storey building the sounders are required to operate continuously on the floor where the activation occurs and intermittently elsewhere.

Assuming each floor comprises one zone only, the sounder modules/ addressable sounders on the floor are assigned to that zone, and the default ringing mode is set to 'Pulsed'. When a device is activated, the associated sounders operate continuously and all others are pulsed.

If, however, each floor comprises more than one zone, the above method is not suitable as only the sounders associated with the activated zone will sound continuously. In this case it is necessary to assign devices to a Group, or Groups.

### **Assigning devices to groups**

The program is not fully flexible as there are only four groups available for programming, but with careful planning and forethought in the installation stage, reasonably complex operating modes can be achieved.

Groups are used to link devices so that, for instance, the activation of a device in any one of several zones can activate common sounders or turn on a particular output.

Each group has options in the way it operates, i.e. Normal, Coincidence or 2-stage. Basically, the selection has the following effect:

- |             |   |
|-------------|---|
| Normal      | The activation of any input device in the group will operate sounders/outputs in the group. Other sounders, i.e. those not in the group, are silent or pulsed depending on the default ring mode. |
| Coincidence | The activation of two or more devices in the group is necessary to operate sounders/outputs in the group.   |
| 2-stage     | The activation of a single input device in the group causes sounders only in the group to pulse; and the activation of a subsequent device causes the sounders to go steady.                      |

Devices may be assigned to one or more groups to achieve the required operation. Sounders and output modules can be assigned to zones and groups, or just groups depending on the required operation. Input devices are always assigned to a zone, irrespective of any groups they may also be assigned to.

#### *Example 2*

In the example above, if each floor comprises, say four zones, the required operation is achieved by assigning the devices in the relevant zones and the applicable sounders to a group (set to Normal).

If additional functions are required such as generating a general alarm when a call point or two or more devices are active, additional groups are set to the appropriate mode and programmed to provide the required result.

Group assignments can be viewed - see page 64.



## Creating a new configuration file

Start the program as described to display the main menu.

Using the cursor (up/down arrow) keys select option 3 Continue and press ENTER (Return), or just press ESC to clear the menu. A blank template is displayed enabling a configuration file to be created, e.g.

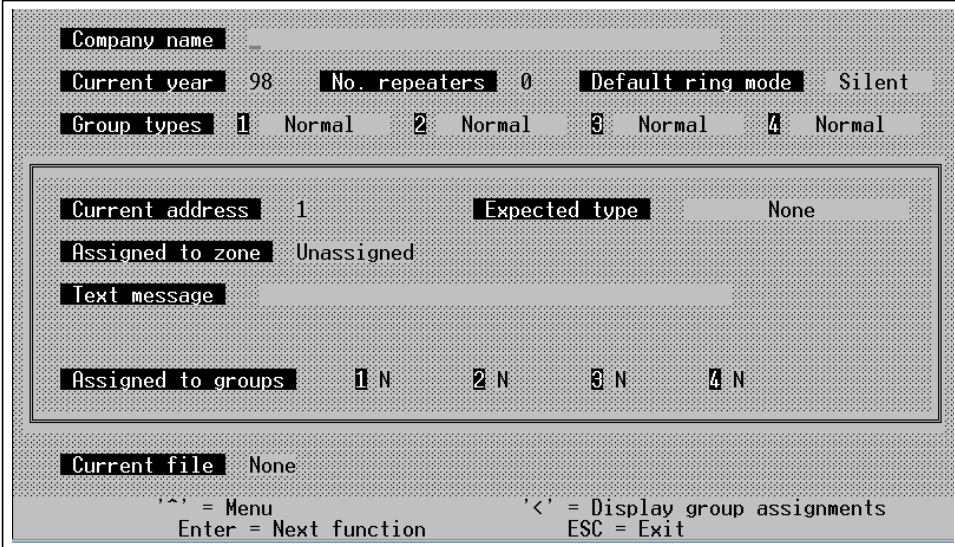

The screenshot shows a configuration editing screen with the following fields and values:

- Company name: [Blank]
- Current year: 98
- No. repeaters: 0
- Default ring mode: Silent
- Group types: 1 Normal, 2 Normal, 3 Normal, 4 Normal
- Current address: 1
- Expected type: None
- Assigned to zone: Unassigned
- Text message: [Blank]
- Assigned to groups: 1 N, 2 N, 3 N, 4 N
- Current file: None

At the bottom, there are control instructions:

- '^' = Menu
- Enter = Next function
- '<' = Display group assignments
- ESC = Exit

Figure 13 - PC Configuration editing screen

### Company name

This field is blank by default. Up to 40 characters of user-defined text are available for displaying the company name or other message .

Use the left/right arrow keys to move the cursor to the desired location. Use the backspace key to delete unwanted characters. Type in the required text.

To centralise the name or message, insert spaces before the text to achieve the desired position.

The text is displayed via the panel LCD in the normal operating mode.

Press ENTER to move to the next field.

### Current year

The current year is derived from the computer clock and should be correct. Adjust if necessary via the up/down arrow keys.

Press ENTER to move to the next field.

### **Number of repeaters**

This field is completed with the number of repeaters installed on the system, in the range 0 to 8. Select the appropriate number using the arrow keys and press ENTER to move to the next field.

### **Default ring mode**

This option determines the operation of sounders not activated by a specific zone or group. Use the up/down keys to make a selection.

Press ENTER to move to the Group type field.

### **Group types**

Each of the four groups can be set to Normal, Coincidence or 2-stage. All output devices in a group will respond to the selected mode. Program the required operation for each group. Press ENTER to move to the Current address field.

### **Current address**

Use the up/down arrow keys to select the required address in the range 1 to 167. The current information for each address is displayed, i.e. zone number, device type and text message. Assuming the device has not previously been programmed, the expected type is 'None' and the zone is 'Unassigned'. The device text field is blank.

Press ENTER to move to the next field.

### **Expected type**

Use the up/down arrow keys to select a device type corresponding to the installed device. The following options are available:

- None
- Call Point
- Temperature
- Optical Detector
- Zone Monitor
- Ionisation Detector
- I/O Interface
- Sounders

**NOTE.** The device type assigned to each address must match the installed device type.

### **Assigned to zone**

Use the up/down arrow keys to select a zone in the range 1 to 16, or, Alarms, Contacts or Inputs, as appropriate. (Refer to panel configuration page 50 for details of operation.)

Press ENTER to move to the next field.

### **Text message**

Up to 40 characters of user-defined text are available for describing the device location or function. Type in the required message using the backspace key to delete unwanted characters. Press ENTER to return the cursor to the device address field to enable further devices to be edited, press ESC.

**NOTE.** Only upper case characters, and numbers 0-9 are available.

### **Assign device to a group**

To assign a device to a group, press the ] (square bracket) key with the cursor in the location text field.

Use the up/down keys to select y (yes) or n (no) to assign the current device to the group. Press ENTER to select the next group, etc.

With the cursor in the group 4 field, press the ENTER key to return the cursor to the current address field.

### **View group assignments**

For an overview of which devices are assigned to each group, press the < (shift + ,) key. Assigned devices are highlighted. Other groups can be selected by pressing the up/down keys. Press ESC to exit.

To return the cursor to the Company name field, press ESC when the cursor is in the current address field.

When the data entry for all devices is complete, press ^ (shift+6) to display the options menu.

The newly created configuration file can be transferred to a novram for insertion in the panel and/or saved to disk.

### **Write data to novram (2)**

Insert the novram into the programmer supplied with the configuration kit,

and plug the programmer into the PC's 25-way printer port (disconnect the printer cable if necessary).

Select the option (2) and press ENTER, or press 2.

A message is displayed with a prompt to 'Press ENTER to continue'. Press ENTER.

The message 'Writing data to novram' is displayed and a series of asterisks indicate the progress of the data transfer, which can take several minutes.

When the data transfer is complete a message is displayed indicating that either the programming was successful or that there was an error. If an error message is displayed check the novram suitability and the programmer connection and repeat the process. If the problem persists consult the supplier.

Assuming the download is successful, press any key to revert to the options menu.

Select 6 - Exit to clear the menu and revert to the program file, or select another option.

To exit the program press ESC twice to display the menu and press 6. A message is displayed advising that data will be lost if not saved to a novram or file. Press Y (yes) to exit or N (no) to revert to the program.

It is recommended that the data is also saved to file for subsequent retrieval if necessary.

#### **Write data to file (4)**

Display the menu and select the option (4). A data form is displayed enabling project/file information to be entered and appended to the file.

Complete the data form with the relevant information. A prompt is displayed requesting confirmation that the information is correct. Enter Y to proceed or N to amend the data.

The program then prompts for a file name. This can be up to eight characters and for ease of retrieval should be a name that corresponds to the job title.

**NOTE:** If the file name only is entered, the file is saved to the current drive and directory. To save the file to a different drive and directory the full path must be entered, e.g. if the program is resident on the C drive of the computer and the file is to be saved to a floppy disk, the following should be typed: a:\filename.

## ***Editing an existing file***

To edit an existing configuration file it must first be retrieved from a novram or a diskfile. It is then amended as required and downloaded to a novram or saved to a diskfile as described above.

### **Read data from novram (1)**

Insert the novram into the programmer and connect the programmer to the PC's parallel printer port.

Start the program and select the option (1) from the menu. Press ENTER at the prompt to start the upload procedure. Press ENTER again when the data transfer is complete.

Press 6 to clear the menu and display the uploaded file. Edit as necessary.

### **Read data from file (3)**

Select the option from the menu. At the prompt enter the file name. Remember, if the target file is not resident on the current drive/directory, the full file path must be entered, e.g. C:\project\filename.

Edit the file as required.

To retain a copy of the file on disk it is necessary to save it using the Write data to file option. To overwrite the current file, type in the same filename (and path if appropriate). Any notes previously appended are displayed and can be accepted or edited as required.

Alternatively, the edited file can be saved separately by giving it a new name, thereby retaining the original file.

### **Print (5)**

To print the file details ensure that the computer is connected to a suitable printer (dot matrix or inkjet type are generally compatible), and that there is paper in the printer.

Highlight the option (5) and press ENTER - the file is immediately sent to the printer and printed out.

## ***Replacing the novram***

**WARNING:** Ensure that all power to the panel is switched off.

Determine the location of the novram on the main PCB by referring to the drawing on page 10.

Using a suitable tool, remove the existing novram from the socket on the main PCB and store safely, or insert in the programmer if re-programming.

Carefully fit the new/revised novram noting the position of pin 1 (indicated by an indent on the novram). Ensure that the pins are correctly aligned with the socket before exerting any force, to avoid bending them.

Re-apply power to the panel. There is a 15 second initialisation period following which the panel should revert to normal operation displaying the time and date.

**NOTE:** If the novram data does not agree with the installed devices, a fault is indicated, e.g. if a device has been deleted from the program, but still exists on the system, or the type does not agree with the installed device, etc.